

Fracture Toughness Investigations of Metal Matrix Composites Using Compact Specimens

Tadeusz SZYMCZAK¹⁾, Zbigniew L. KOWALEWSKI^{1), 2)}

¹⁾ *Motor Transport Institute
Centre for Material Testing and Mechatronics*

Jagiellońska 80, 03-301 Warsaw, Poland
e-mail: tadeusz.szymczak@its.waw.pl

²⁾ *Institute of Fundamental Technological Research PAN
Department for Strength of Materials*

Pawińskiego 5B, 02-106 Warsaw, Poland

This paper presents experimental results of the fracture toughness tests carried out on metal matrix composites. The material was produced using the 44200 aluminium alloy reinforced by Al_2O_3 in the form of Saffil fibres. Three different contents of Al_2O_3 were taken into account, i.e. 10%, 15%, 20%. The main aim of the research was to examine an influence of the aluminium oxide content on a critical value of the stress intensity factor, K_{IC} . All tests were performed using a miniature compact specimen, which was four times smaller than the typical one. The results of FEA analysis confirmed a typical distribution of the effective stress at the tip of the notch. In each test the composite specimen was mounted in the loading system of the testing machine by applying special grips. Crack tip opening displacement of the specimen notch was measured by means of the clip on knife edge extensometer having 10 mm gauge length. The results in form of tensile force versus crack tip opening displacement show the first mode of fracture. An inspection of the pre-cracked zone of the composite did not exhibit the typical features usually observed on specimen surface after fatigue. An influence of the Al_2O_3 Saffil fibres content within the range from 10% to 20% on a critical value of the stress intensity factor was negligible small. The K_{IC} of the composites tested in this research achieved the level of 12 MPa m^{1/2}.

Key words: metal matrix composite, fracture toughness test, compact specimen, fatigue zone, stress intensity factor.

1. INTRODUCTION

Classification of modern materials for engineering applications requires knowledge about their mechanical parameters. Among many of such parameters one can distinguish: Young's modulus, proportional limit, yield point, ultimate tensile strength, and stress intensity factor (SIF or K_I). It is known that SIF de-

scribes material resistance to brittle cracking. The stress intensity factor is investigated using specimens having a notch containing the fatigue crack at its tip and by applying the following stages of the experimental procedure: (a) pre-cracking of fatigue zone, and (b) testing under monotonic tension [1]. Several types of specimen are used, i.e.: compact tension (CT) [2, 3]; disk-shaped [3]; single edge [3]; single or middle notched [2, 4]. In many experimental cases, the dimension of the specimen is limited by a material volume. Therefore, different sizes of specimen can be applied, i.e. standard [3], miniature (Fig. 1) [4, 5], or mini (Fig. 2) [6].

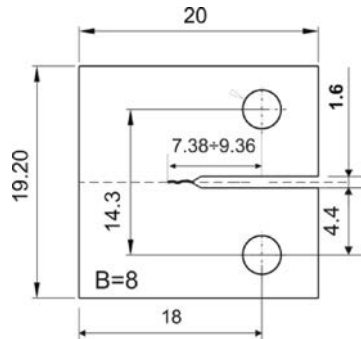

FIG. 1. Miniature compact specimen [5].

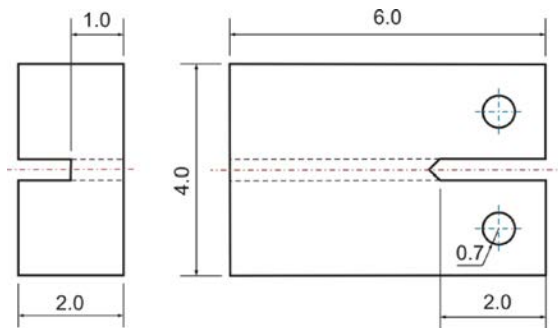

FIG. 2. Mini-compact specimen [6].

The objective of this paper is to determine a critical value of the stress intensity factor of a metal matrix composite (MMC) reinforced by the Saffil ceramic fibres.

As reported in [7, 8] the ultimate tensile strength and the Young's modulus of this type of reinforcement are equal to 1800 MPa and 300 GPa, respectively. The fibres can be applied in many engineering applications operated even at the temperature of up to 1750°C [9]. The results of experiments also show that the content of the fibres influences material hardening. In the case of 2014 aluminium alloy, this effect, at both room and elevated temperature of 360°C,

was significantly higher than in the case of an unreinforced material [10]. Young's modulus achieved 22% increase at the fibre content equal to 10%, but for greater fibre volume fraction a gradual lowering of this parameter occurred. Finally, this parameter achieved 13% reduction compared to the base material without the reinforcement. Here, 10% of Al_2O_3 content caused 86% and 77% increase of the yield point and ultimate tensile strength determined at the temperature of 270°C , respectively.

2. EXPERIMENTAL RESULTS

The 44200 aluminium alloy [11] (AK11 according to Polish Standards PN-76/H-88027) reinforced by a different content of Al_2O_3 Saffil ceramic fibres, i.e. 10%, 15%, and 20%, were selected for investigation. All tests were performed using compact tension specimens (CT). With respect to a limited volume of the composite, the applied specimen was four times smaller than the typical one, and therefore, the experimental procedure contained two stages. The first step focused on examination of the specimen size by means of finite element analysis (FEA) and tests on the 40H steel, while the second stage concentrated on determining a critical value of the stress intensity factor of the composite.

2.1. Specimen and validation process

The compact tension specimen (Fig. 3), was designed on the basis of the ASTM [3] and PN-EN [12] guidelines. The specimen thickness was equal to the minimum recommended value, i.e. 6.5 mm, enabling examination of the material under plane strain state.

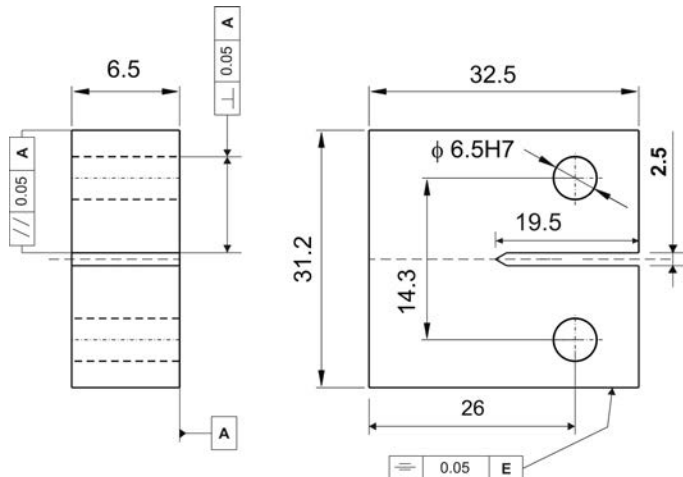

FIG. 3. Dimensions of the compact tension specimen (CT).

Further, the specimen geometry (Fig. 4a) was validated using FEA. The loading and boundary conditions were similar to those applied in the servo-hydraulic testing machine, as shown in Fig. 4b, c. The specimen was modelled as the fully elastic material and using 3D solid that was divided into 374088 3D elements stretched on 528467 nodes, Fig. 4c. Selected results, i.e. standardized values of the Huber-Mises-Hencky's effective stress at the tip of notch, are given in Fig. 5. The results indicate a typical distribution of the effective stress.

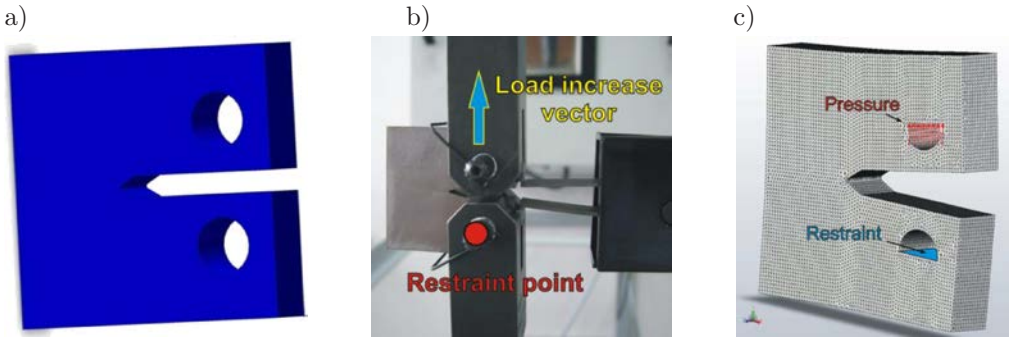

FIG. 4. Compact tension specimen: a) shape in 3D coordinates system, b) the real attachment, c) 3D mesh elements, simulated loading and boundary conditions by pressure and restraint.

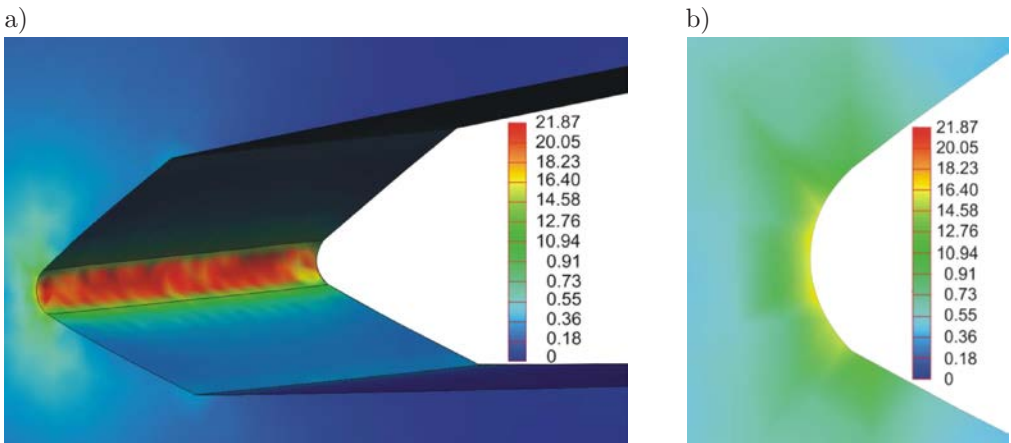

FIG. 5. Variation of the effective standardized stress at the tip of the notch, calculated using the Huber-Mises-Hencky's criterion, i.e.: a) 3D view, b) 2D view in front of the notch.

A validation of the specimen geometry on the basis of fracture toughness tests on the 40H steel was the first step of the procedure. For this type of material, a fatigue zone was successfully pre-cracked, Fig. 6a. Crack features of length equal

to 2.08 mm (Fig. 6b) and fatigue bands (Fig. 7) were determined at different magnification using the Scanning Electron Microscope (SEM). A critical value of the stress intensity factor of the 40H steel achieved the level of $38.8 \text{ MPa m}^{1/2}$ (close to the literature value equal to $40 \text{ MPa m}^{1/2}$).

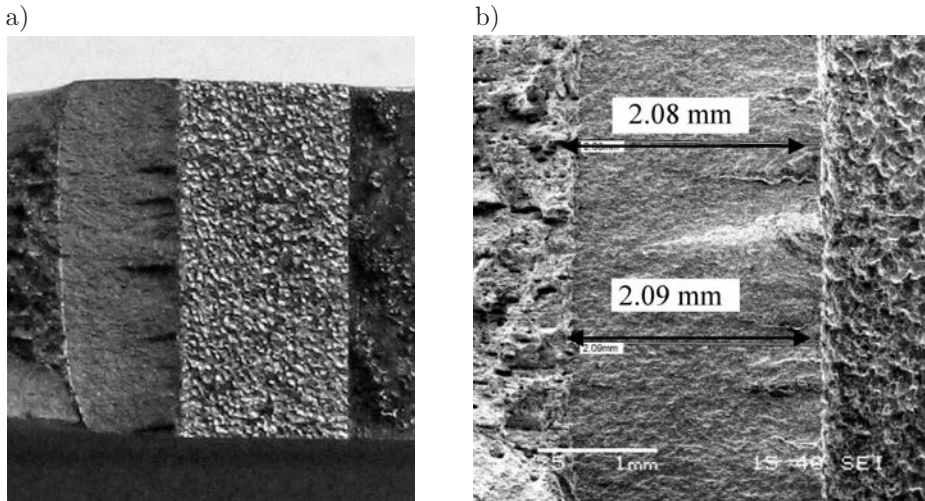

FIG. 6. Fracture surface of the 40H steel after fracture toughness testing: a) fatigue zone in macro scale, b) fatigue zone in micro scale (magnification $25\times$).

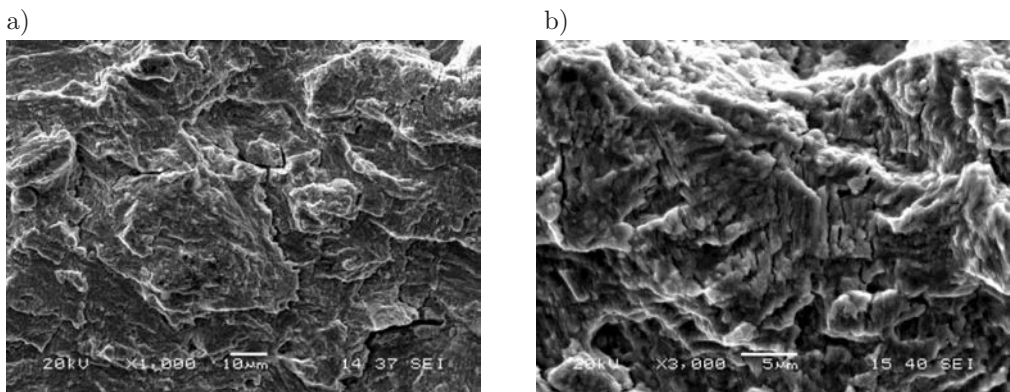

FIG. 7. Microscope image of a fatigue fracture surface of the 40H steel after fracture toughness testing: a) magnification $1000\times$, b) magnification $3000\times$.

2.2. Investigation of fracture toughness for the composites

In comparison to the typical engineering materials the composites were very difficult in machining. Therefore, preparation of the specimens (Figs. 3, 8a) at the recommended accuracy class required usage of more stages of the technological process than in the case of typical materials.

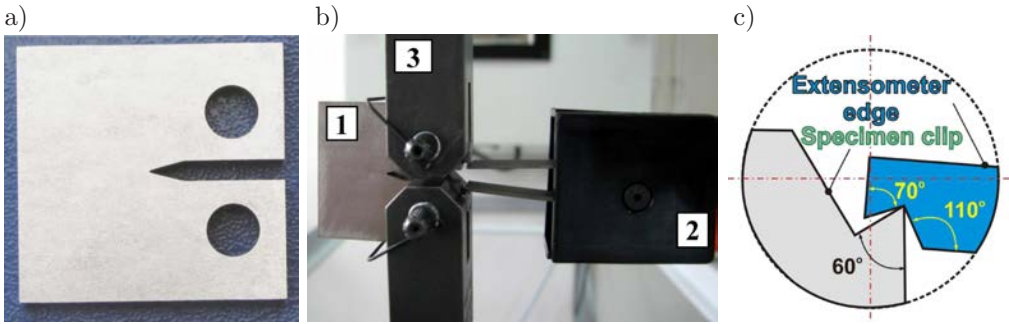

FIG. 8. Manufactured specimen: a) before testing, b) mounted in the loading system of the testing machine: 1 – specimen, 2 – extensometer, 3 – grips, c) knife-edge bearing (according to ASTM Standards [3]).

All fracture toughness tests were conducted using the 8802 Instron servo-hydraulic testing machine at room temperature. The specimens were mounted in the loading system by application of the special grips, Fig. 8b. Crack tip opening displacement was measured by means of the clip on knife edge extensometer of 10 mm gauge length; Figs. 8b, c.

In the case of all composite specimens the fatigue zone was successfully pre-cracked, and then, the materials were tested under monotonically increasing tensile force using the commercial programme for K_{IC} determination.

The crack propagated in the perpendicular direction to the opposite side of the specimen independently of the content of Al_2O_3 Saffil fibres (Figs. 9, 10, 12). Each specimen was observed at a different magnification to distinguish features of the fracture surface (Fig. 12b, 13). A macro-scale observation indicated several sections on this surface, i.e. (1) fatigue, (2) fracture, (3) sloping fracture, and (4) tearing; Figs. 12b, c. This expresses a disturbance of the plane strain state and exhibits composite fracture as that under mixed stress/strain conditions obtained.

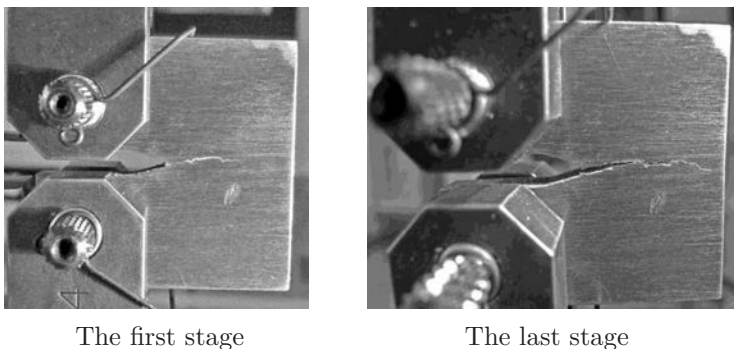

FIG. 9. Rupture stages of the specimen made of the 44200+10% Al_2O_3 Saffil fibre composite.

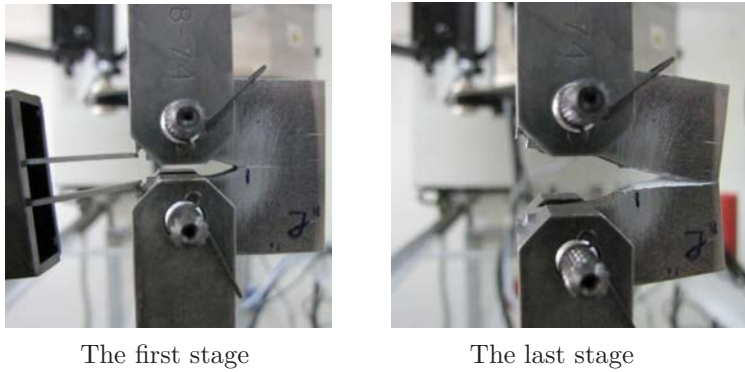

FIG. 10. Rupture stages of the specimen made of the 44200+20% Al₂O₃ Saffil fibre composite.



FIG. 11. Specimen made of the 44200+10% Saffil fibres composite after tests for K_{IC}:
a) specimen, b) entire fracture surface.

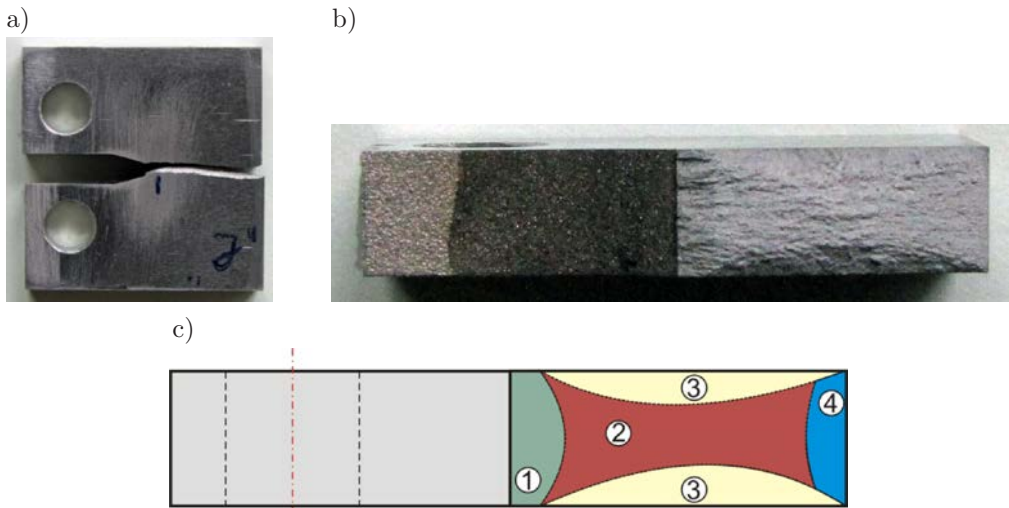
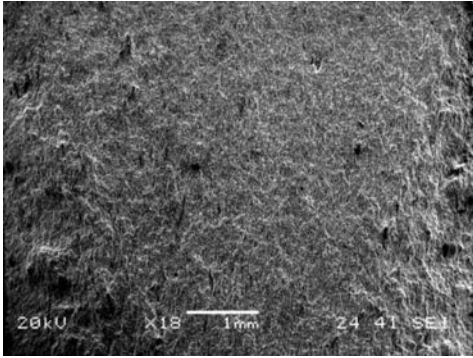

FIG. 12. Specimen made of the 44200+20% Saffil fibre composite after tests for K_{IC}: a) specimen, b) entire fracture surface, c) fracture surface scheme: 1 – fatigue area, 2 – fracture zone, 3 – sloping fracture surfaces, and 4 – tearing zone.

A microscopic analysis of the fatigue fracture surface was performed at magnification equal to 18 (Fig. 13a), 100 (Fig. 13b), 1000 (Fig. 14a), and 2500 (Fig. 14b). The results did not exhibit any of the typical features observed on the specimen surface after fatigue testing. Moreover, a local delamination of the structure was observed in the case of composite with 20% Al_2O_3 Saffil fibre content (Figs. 14a, b). It occurred in the form of voids between the matrix and fibres Fig. 14b.

a)



b)

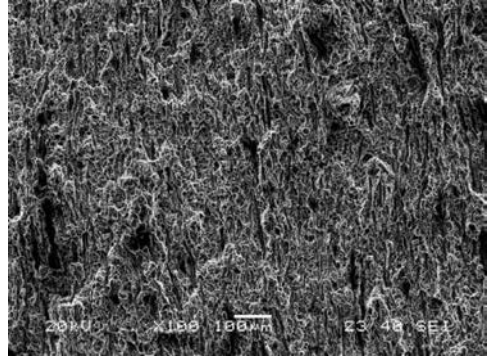
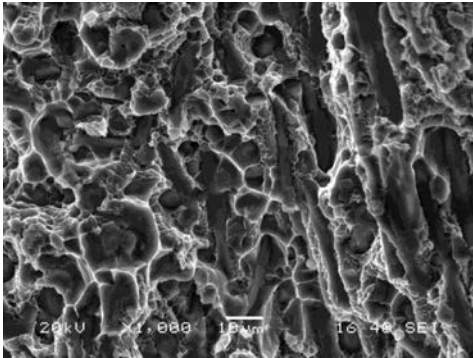

FIG. 13. Microscopic images of fatigue fracture surface of the 44200+20% Saffil fibre composite: a) magnification 18 \times , b) magnification 100 \times .

a)



b)

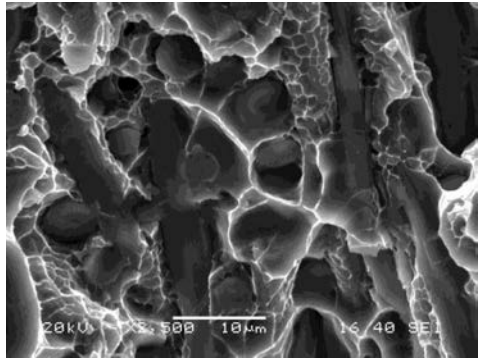

FIG. 14. Microscopic images of fatigue fracture surface of the 44200+20% Saffil fibre composite: a) magnification 1000 \times , b) magnification 2500 \times .

Variation of the tensile force versus crack tip opening displacement identifies the first mode of fracture, Fig. 15. An initial section of that characteristic was approximated using linear functions, Fig. 15b. This shows an influence of the Al_2O_3 Saffil fibres content on a variation of the proportionality coefficient. This parameter was increasing linearly with an increase of the fibres content. In the case of composite containing 10%, 15%, and 20% of the Al_2O_3 Saffil

fibres, it achieved the level of 10233.44, 10897.65, and 13120.61 respectively; Figs. 15b, 16.

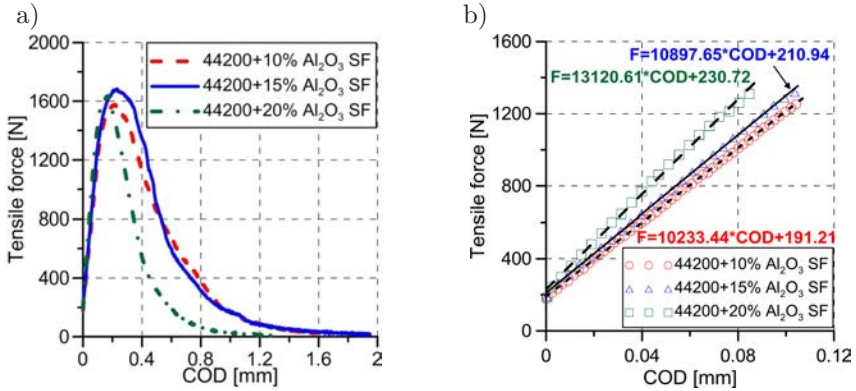

FIG. 15. Tensile force versus COD (a), linear section of diagrams presented in Fig. 15a.

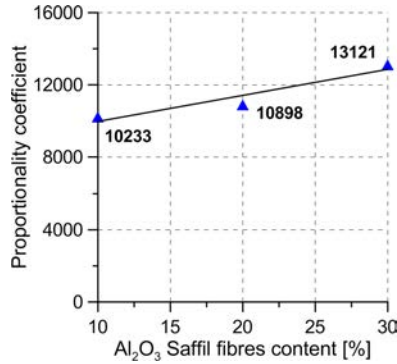

FIG. 16. Variations of the proportionality coefficient of function shown in Fig. 15b.

The relationship between the tensile force and crack tip opening displacement was analysed with respect to variation of the fracture energy. It was calculated as the area below the curves presented in Fig. 15. As shown in Fig. 17, this

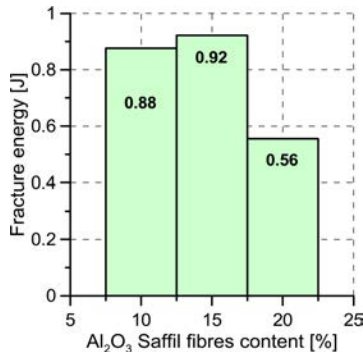

FIG. 17. Fracture energy against the Al₂O₃ Saffil fibres content.

parameter does not confirm any particular tendency, although variations of the proportionality coefficient were increasing linearly.

The critical values of the stress intensity factor of the 44200 aluminium alloy reinforced by various content of the Saffil fibres, i.e. 10% ,15%, 20%, reached the following levels: 12.201, 12.121, and 11.866 [MPam^{1/2}], respectively. It is easy to conclude, that these values are three times smaller than those determined for the 40H steel. It seems that the fracture toughness of the composites tested is not high enough to be use especially for the very responsible elements of engineering constructions.

3. SUMMARY

The paper presents experimental data from the fracture toughness tests conducted on the 44200 casting aluminium alloy reinforced by the Al₂O₃ Saffil ceramic fibre. Analyses of the results make it possible to formulate the following remarks:

- a) four times smaller specimen than the typical one can successfully be applied to determine a critical value of the stress intensity factor;
- b) pre-cracked zone in the composite did not has typical features usually observed on the specimen surface after fatigue;
- c) influence of the Al₂O₃ Saffil fibres content within the range from 10% to 20%, on the critical stress intensity factor was negligible small;
- d) critical value of the stress intensity factor of the composite was three times smaller than that for the 40H steel achieved.

ACKNOWLEDGMENT

This paper was supported by the KomCerMet project (contract No. POIG. 01.03.01-14-013/08-00 founded by the Polish Ministry of Science and Higher Education) in the framework of the Operational Programme Innovative Economy in the years 2007–2013.

REFERENCES

1. DOBRZAŃSKI L., NOWOSIELSKI R., *Testing of metals and alloys*, vol. I, "Investigations of mechanical and physical properties" [in Polish], Silesia University of Technology, Gliwice 1986.
2. DOGA B., CEYHAN U., NIKBIN K.M., PETROVSKI B., DEAN D.W., *European code of practice of creep crack initiation and growth testing of industrial relevant specimens*, Journal of ASTM International, **3**, 2, 20, 2006.

3. Standard Test Method for Plane-Strain Fracture Toughness of Metallic Materials, Annual Book of ASTM Standards, *Metals Test Methods and Analytical Procedures, Metals-Mechanical Testing: Elevated and Low-Temperature Tests*, Metallography, **03.01**, 509–539, 1993.
4. KALLURI S., TELESMA J., *Characterization of fatigue crack initiation and propagation in Ti-6Al-4V with electrical potential drop technique*, NASA Technical Memorandum 100877, July 1988.
5. GOLERTHAN S., HERBERG D., BARUJ A., EGGELER G., *Compact tension testing of martensitic/pseudoplastic NiTi shape memory alloys*, Materials Science Engineering, **481–482**, 156–159, 2008.
6. BAJAJ D., SUNDARAM N., AROLA D., *Striations resulting from fatigue crack growth in dentin*, [in:] Fractography of Glasses and Ceramics V: Ceramic Transactions, James R. Varner, George D. Quinn, Marlene Wightman, **199**, 2007.
7. DIERINGA H., HORT N., KAINER K.U., *Compression creep of short fibre reinforced magnesium alloy AE42*, Composites, **3**, 7, 275–278, 2003.
8. NAPLOCHA K., KACZMAR J.W., *Tribological properties of Al 7075 alloy based composites strengthened with Al₂O₃ fibres*, Archives of Foundry Engineering, **11**, Special Issue 2, 30/2, 153–158, 2011.
9. http://www.saffil.com/index/fibre_home/property_information.aspx.
10. SAMUEL M., *Reinforcement of recycled aluminium-alloy scrap with Saffil ceramic fibres*, Journal of Materials Processing Technology, **142**, 295–306, 2003.
11. PN-EN 1676:2011, *Aluminium and aluminium alloys – Alloy ingots for remelting – Specifications*, 2011.
12. PN-EN ISO 12737: 2011, *Metals – Fracture toughness at biaxial strain state*, 2011.

Received March 6, 2013; revised version June 11, 2013.
